

AR type

Easy Cut Radius Mill AR



MOLDINO Tool Engineering, Ltd.

New Product News | No.1209E-12 | 2026-2

**Powerful to
Deep Milling**

**Ace Of The Direct
Milling**

**Suitable For
Three-dimensional
Rough Milling**

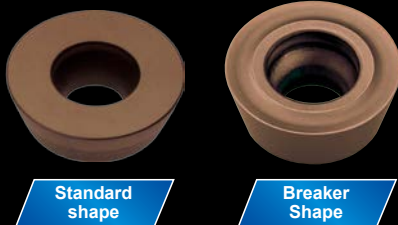

Standard
Shape

Breaker
Shape

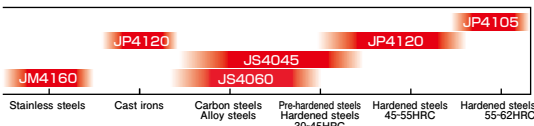

Applications

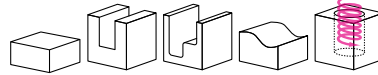

AJ Coating series

JP4120

JP4105

JM4160

Features of AJ Coating series

- Employs an AlTiN layer with a new composition created by increasing the Al content of conventional layers.
- Excellent wear resistance, chipping resistance, and heat resistance!

New technology!!

- The new layer with high Al content employs a new composition and optimizes the structure to improve wear resistance and chipping resistance!
- Employs a low-friction-effect coating with excellent welding resistance as the top-most surface layer. This reduces welding to the work and decreases cutting force!

Layer structure AJ Coating

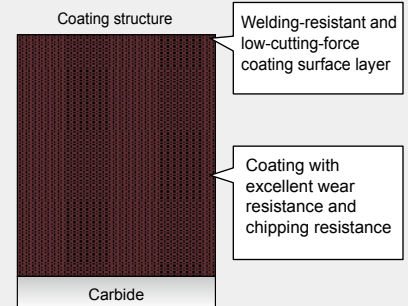

PVD Technology

Grade for machining pre-hardened or hardened materials **JP4120**

Features

- Employs a fine carbide substrate with an excellent balance between wear resistance and toughness and the new "AJ Coating" to provide improved wear resistance and chipping resistance.
- Highly versatile with excellent wear resistance and chipping resistance when machining steel materials with hardnesses of 30 to 50 HRC.

Strong fields

- Exhibits excellent cutting performance when machining pre-hardened or hardened steels with hardnesses of 30 to 50 HRC.
- Exhibits excellent wear resistance even on difficult-to-cut diecast tool steels or precipitation-hardened stainless steels, or for finishing.

Cutting performance

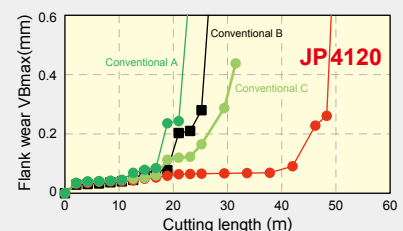

Work material : P21 (40HRC)
 Tool : ASRT5063R-4
 Insert : WDNW140520
 Cutting conditions :
 $v_c=90\text{m/min}$ $f_z=0.8\text{mm/t}$ $a_p \times a_e=1 \times 44\text{mm}$
 Dry ※Single-flute cutting

PVD Technology

Grade for machining stainless-steel materials JM4160

Features

- Employs a carbide substrate with high toughness and the new "AJ Coating" to improve wear resistance and chipping resistance when machining stainless-steel materials.
- Employs AJ Coating with excellent welding resistance to reduce the welding to work material that occurs when machining stainless steel materials.

Strong fields

- Provides long tool life for general processing of stainless-steel materials.

Cutting performance

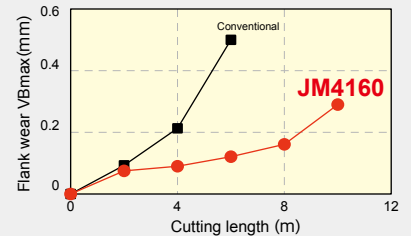

Work material : SUS304
 Tool : ASRS2032R-5
 Insert : EPMT0603EN-8LF
 Cutting conditions :
 $v_c=180\text{m/min}$ $f_z=0.5\text{mm/t}$ $a_p \times a_e=0.8 \times 21\text{mm}$
 Wet ※ Single-flute cutting

PVD Technology

Grade for machining high-hardness materials JP4105

Features

- Employs an ultra-fine cemented carbide substrate and the new "AJ Coating" to improve wear resistance.
- Excellent wear resistance when machining high hardness materials of 50HRC or higher.

Strong fields

- Hardened steels (50 to 60 HRC): SKD11, SKD61, SKH, SUS420, etc.

Cutting performance

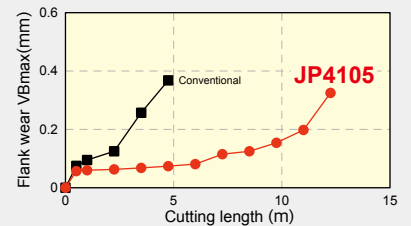

Work material : SKD11(61HRC) Tool : ASRS2032-5
 Insert : EPNW0603TN-8
 Cutting conditions :
 $v_c=80\text{m/min}$ $f_z=0.2\text{mm/t}$ $a_p \times a_e=0.5 \times 21\text{mm}$
 Dry ※ Single-flute cutting

PVD Technology

General purpose for steel JS4045

Features

- JS4045 adopts heat resistant layer, reduces the crater wear by high-speed cutting.
- JS4045 adopts heat resistant substrate, reduces the wear and improves tool life.
- Improves tool life on dry cutting.

Strong fields

- Continuous and light interrupted cutting of less than 35HRC dry cutting.

Layer structure JS coating

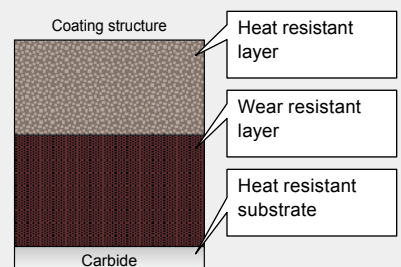

Wear graph after cutting SCM440 (32HRC)

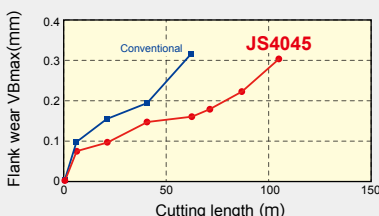

Cutting Conditions

Work Material SCM440(32HRC)
 Tool ASR5063-4
 Insert Model EDNW15T4TN-15
 Cutting Speed $v_c = 180\text{m/min}$
 Speed per flute $f_z = 1.5\text{mm/t}$
 Cutting depth $a_p \times a_e = 1.0 \times 42\text{mm}$
 Coolant Dry cutting
 Single-flute cutting

Wear graph after cutting P20 (32HRC)

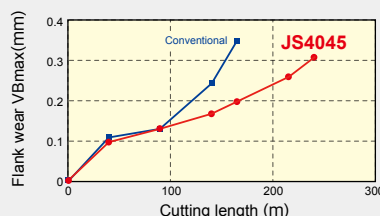

Cutting Conditions

Work Material P20(32HRC)
 Tool ASRS2016R-2
 Insert Model EPNW0603TN-8
 Cutting Speed $v_c = 180\text{m/min}$
 Speed per flute $f_z = 1.5\text{mm/t}$
 Cutting depth $a_p \times a_e = 0.5 \times 13\text{mm}$
 Coolant Dry cutting
 Single-flute cutting

Line Up

Shank type AR R

Numeric figure in a circle ○ and alphabetical character comes in a square □.

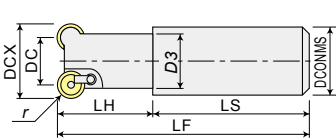

Fig.1

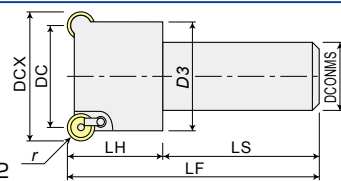







Fig.2

	Item code	Stock	No. of flutes	Size (mm)									Shape	Inserts	
				DCX	DC	LF	DCONMS	r	LH	LS	D3				
Straight shank type	Regular	※ ARS0020R	●	2	20	12	130	20	4	50	80	18	Fig.1	RDHW0802M0TN RDMT0802M0TN RDMT0802M0EN	
		※ ARS3025R	●	2	25	15	140	25	5	60	80	21		Fig.1	RDHW10T3M0TN RDMT10T3M0TN RDMT10T3M0EN
		※ ARS3030R	●	3	30	20	150	32	5	70	80	26			Fig.2
		※ ARS3032R	●	3	32	22	150	32	5	70	80	28	Fig.2		
		※ ARS4040R	●	3	40	28	150	32	6	50	100	35		Fig.2	
		※ ARS4050R	●	3	50	38	150	32	6	50	100	45			Fig.2
		※ ARS4050R42	●	4	50	38	150	42	6	50	100	45	Fig.2		
		ARS5040R	●	2	40	24	150	32	8	50	100	35		Fig.2	
		ARS5050R	●	3	50	34	150	32	8	50	100	44			Fig.2
		ARS5050R42	●	3	50	34	150	42	8	50	100	44	Fig.2		
ARS5063R	●	3	63	47	150	32	8	50	100	58	Fig.2	RDHW1604M0TN RDMX1604M0TN RDMX1604M0EN RDMT1604M0TN RDMT1604M0EN			
ARS5063R42	●	3	63	47	150	42	8	50	100	58		Fig.2		RDHW1604M0TN RDMX1604M0TN RDMX1604M0EN RDMT1604M0TN RDMT1604M0EN	
Straight shank type	Long	※ ARL0020R	●	2	20	12	180	20	4	100			80	18	Fig.1
		※ ARL3025R	●	2	25	15	200	25	5	120	80		21	Fig.1	
		※ ARL3030R	●	3	30	20	200	32	5	120	80	26	Fig.2		
		※ ARL3032R	●	3	32	22	200	32	5	120	80	28			Fig.2
		※ ARL4032R	●	2	32	20	250	32	6	150	100	28		Fig.2	
		※ ARL4040R	●	3	40	28	250	32	6	50	200	35	Fig.2		
		※ ARL4050R42	●	4	50	38	250	42	6	50	200	45			Fig.2
		ARL5040R	●	2	40	24	250	32	8	50	200	35		Fig.2	
		ARL5050R42	●	3	50	34	250	42	8	50	200	44	Fig.2		
		ARL5063R42	●	3	63	47	250	42	8	50	200	58			Fig.2
Straight shank type	Extra Long	※ ARE0020R	●	2	20	12	250	20	4	130	120	18		Fig.1	
		※ ARE3025R	●	2	25	15	300	25	5	180	120	21	Fig.1		
		※ ARE3030R	●	2	30	20	300	32	5	180	120	26			Fig.2
		※ ARE3032R	●	3	32	22	300	32	5	180	120	28		Fig.2	
		※ ARE4032R	●	2	32	20	300	32	6	180	120	28	Fig.2		
		※ ARE4040R	●	2	40	28	300	32	6	50	250	35			Fig.2
		※ ARE4050R42	●	2	50	38	300	42	6	50	250	45		Fig.2	
		ARE5040R	●	2	40	24	300	32	8	50	200	35	Fig.2		
ARE5050R42	●	3	50	34	300	42	8	50	200	44	Fig.2	RDHW1604M0TN RDMX1604M0TN RDMX1604M0EN RDMT1604M0TN RDMT1604M0EN			
ARE5063R42	●	3	63	47	300	42	8	50	200	58		Fig.2		RDHW1604M0TN RDMX1604M0TN RDMX1604M0EN RDMT1604M0TN RDMT1604M0EN	

※:With air-hole.

Parts

Parts	Clamp screw for Inserts	Clamp piece set	Clamp piece	Clamp screw for Clamp piece	Spring	Screw driver/ Wrench	Shape
Shape							Shape
Cutter body		fastening torque (N·m)					
ARS/L/E0020R	261-140	1.1	CM3.5-141	—	—	—	104-T8 A
ARS/L/E3025R~ARS/L/E3032R	501-161	2.9	CM3.5-141	—	—	—	104-T15 A
ARS/L/E4032R~ARS/L/E4050R(42)	262-142	2.9	CM4-141	—	—	—	104-T15 A
ARS/L5040R~ARS/L5063R(42)	223-141	4.9	—	215-192	200-150	715-201	105-T20 B

[Note] The clamp screw is a consumable part. Since replacement life depends on the use environment, it is recommended that it be replaced at an early stage.

● : Stocked Items.

Modular type

ARM○○○○R-○

Numeric figure in a circle ○

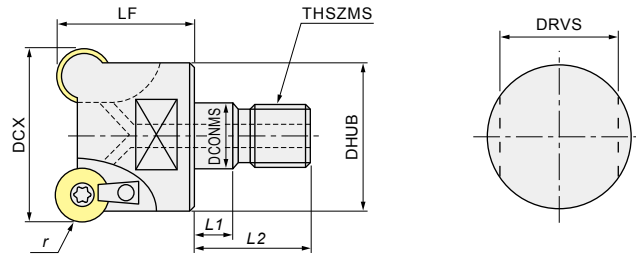

Item code	Stock	No. of flutes	Size (mm)									Inserts
			DCX	r	LF	DCONMS	THSZMS	DHUB	L1	L2	DRVS	
※ ₁ ARM0512R-2	●	2	12	2.5	20	6.5	M6	9.8	5.5	14.5	7	RDMW0501M0EN
※ ₁ ARM0512R-3	●	3	12	2.5	20	6.5	M6	9.8	5.5	14.5	7	
ARM0716R-2	●	2	16	3.5	25	8.5	M8	12.8	5.5	17	10	RDMW0702M0EN
ARM0020R-2	●	2	20	4	30	10.5	M10	17.8	5.5	19	15	RDHW0802M0TN RDMT0802M0TN RDMT0802M0EN
※ ARM0022R-2	●	2	22	4	30	10.5	M10	17.8	5.5	19	15	
ARM3025R-2	●	2	25	5	35	12.5	M12	20.8	5.5	22	17	RDHW10T3M0TN RDMT10T3M0TN RDMT10T3M0EN
※ ARM3028R-2	●	2	28	5	35	12.5	M12	23	5.5	22	17	
ARM3030R-3	●	3	30	5	40	17	M16	28.8	6	23	22	
ARM3032R-2	●	2	32	5	40	17	M16	28.8	6	23	22	
ARM3032R-3	●	3	32	5	40	17	M16	28.8	6	23	22	
※ ARM3040R-4	●	4	40	5	40	17	M16	28.8	6	23	22	

[Note] ① When ※ and carbide shank are used together as a set, there is no interference. ② ※₁ with tool dia. (DCX) of φ12 do not have air holes.
 ③ Do not apply lubricants such as grease, etc. to the "contact faces" and "modular screws" of the "modular mill", "dedicated shanks" and "dedicated arbor".

Parts

Parts	Clamp screw		Clamp piece set	Screw Driver	Screw anti-seizure agent
Shape					
Cutter body		fastening torque (N·m)			
ARM0512R-○	240-140	0.4	—	104-T6	P-37
ARM0716R-2	250-141	1.1	—	104-T8	
ARM0020R-2	261-140	1.1	CM3.5-141	104-T8	
ARM0022R-2				104-T15	
ARM3025R-2	501-161	2.9	CM3.5-141	104-T15	
ARM3028R-2					
ARM3030R-3					
ARM3032R-○					
ARM3040R-4					

[Note] The clamp screw is a consumable part. Since replacement life depends on the use environment, it is recommended that it be replaced at an early stage.

Line Up

Bore type ARB○○○○R-○(M) AR5○○○○R

Numeric figure in a circle ○

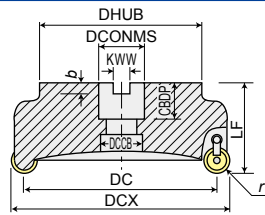

Fig.3

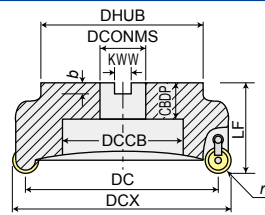

Fig.4

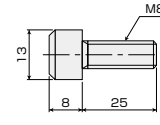

Fig.5

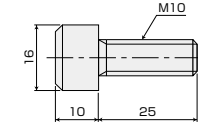

Fig.6

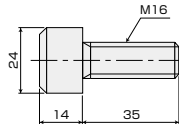

Fig.7

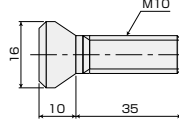

Fig.8 100-211

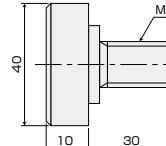

Fig.9

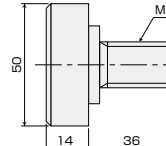

Fig.10 600-211

Item code	Stock	No. of flutes	Size (mm)										Shape	Inserts			
			DCX	DC	DHUB	r	LF	DCONMS	DCCB	KWW	b	CBDP			Arbor screw		
Bore type Outside diameter type	ARB4040R-3	●	3	40	28	32	6	50	16	13.5	8.4	5.6	19	M8×25 (Fig.5)	Fig.3	RDHW1204M0TN RDMT1204M0TN RDMT1204M0EN	
	ARB4050R-3	●	3	50	38	48	6	50	22.225	17	8.4	5	19	M10×25 (Fig.6)			
	ARB4050R-5	●	5	50	38	48	6	50	22.225	17	8.4	5	19	M10×25 (Fig.6)			
	ARB4050R-3M	●	3	50	38	48	6	50	22	17	10.4	6.3	20	M10×25 (Fig.6)			
	ARB4050R-5M	●	5	50	38	48	6	50	22	17	10.4	6.3	20	M10×25 (Fig.6)			
	ARB4063R-4	●	4	63	51	61	6	50	22.225	17	8.4	5	19	M10×25 (Fig.6)			
	ARB4063R-6	●	6	63	51	61	6	50	22.225	17	8.4	5	19	M10×25 (Fig.6)			
	ARB4063R-4M	●	4	63	51	61	6	50	22	17	10.4	6.3	20	M10×25 (Fig.6)			
	ARB4063R-6M	●	6	63	51	61	6	50	22	17	10.4	6.3	20	M10×25 (Fig.6)			
	ARB4080R-4	●	4	80	68	76	6	70	31.75	26	12.7	8	32	M16×35 (Fig.7)			
	ARB4080R-6	●	6	80	68	76	6	70	31.75	26	12.7	8	32	M16×35 (Fig.7)			
	ARB4100R-5	●	5	100	88	96	6	70	31.75	26	12.7	8	32	M16×35 (Fig.7)			
	ARB4125R-6	●	6	125	113	102	6	70	38.1	55	15.9	10	38	M20 (Fig.10)			Fig.4
	ARB5063R-3	●	3	63	47	61	8	50	22.225	17	8.4	5	19	M10×25 (Fig.6)			Fig.3
ARB5080R-4	●	4	80	64	76	8	70	31.75	26	12.7	8	32	M16×35 (Fig.7)				
ARB5100R-5	●	5	100	84	96	8	70	31.75	26	12.7	8	32	M16×35 (Fig.7)				
ARB5125R-6	●	6	125	109	102	8	70	38.1	55	15.9	10	38	M20 (Fig.10)	Fig.4			
Tip end type	AR5047R	●	3	63	47	47	8	47	22.225	16.5	8.4	5	19	M10 (Fig.8)	Fig.3	RDHW1604M0TN RDMX1604M0TN RDMX1604M0EN RDMT1604M0TN RDMT1604M0EN	
	AR5080R	●	4	96	80	65	8	63	31.75	43	12.7	8	32	M16 (Fig.9)			
	AR5100R	●	5	116	100	85	8	63	38.1	53	15.9	10	38	M20 (Fig.10)			
	AR5125R	●	6	141	125	85	8	63	38.1	60	15.9	10	38	M20 (Fig.10)			

[Note] Arbor screws for cutter as yours are not equipped with cutter bodies. AR5047R exceptionally has arbor screws (100-211).

Parts

Numeric figure in a circle ○

Parts	Clamp screw for inserts	Clamp piece set	Clamp piece	Clamp screw for clamp piece	Spring	Wrench	Screw anti-seizure agent
Shape							
Cutter body	Fastening torque (N·m)						
ARB4○○○○R-○(M)	262-142	2.9	CM4-141	—	—	105-T15	P-37
ARB5○○○○R-○	263-141	4.9	CM5-147	—	—	105-T20	
AR5○○○○R	223-141	4.9	—	215-192	200-150	715-201	

[Note] The clamp screw is a consumable part. Since replacement life depends on the use environment, it is recommended that it be replaced at an early stage.

Inserts

Numeric figure in a circle ○

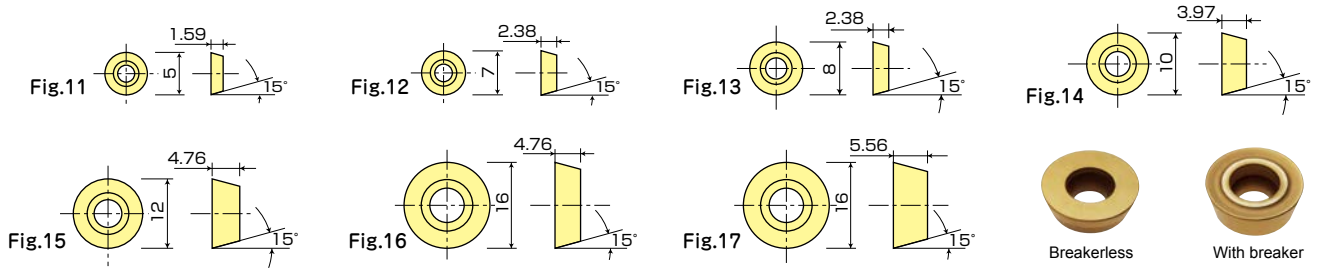

Item code	Tolerance class	Al Coating			JS Coating		TH Coating	C Coating		G Coating	K	Shape	Cutter body
		JP4105	JP4120	JM4160	JS4045	JS4060	PTH08M	CY100H	CY250	GF30	WH10		
RDMW0501M0EN	M breakerless	●*		●			●	●				Fig. 11	ARM0512R-2 ARM0512R-3
RDMW0702M0EN	M breakerless	●*		●			●	●				Fig. 12	ARM0716R-2
RDHW0802M0TN	H breakerless			●	●			●				Fig. 13	ARS0020R ARL0020R ARE0020R
RDMT0802M0TN	M with breaker	●	●	●	●	●		●					ARM0020R-2 ARM0022R-2
RDHW10T3M0TN	H breakerless				●			●				Fig. 14	ARS30○○R ARL30○○R ARE30○○R
RDMT10T3M0TN	M with breaker	●	●	●	●	●		●	●				ARM3025R-2 ARM3040R-4
RDHW1204M0TN	H breakerless				●			●				Fig. 15	ARS40○○R (42) ARL40○○R (42) ARE40○○R
RDMT1204M0TN	M with breaker	●	●	●	●	●		●					ARB4○○○R-○(M)
RDHW1604M0TN	H breakerless				●			●				Fig. 16	ARS50○○R (42) ARL50○○R (42) ARE50○○R (42)
RDMT1604M0TN	M with breaker	●	●	●	●	●		●					AR5○○○R
RDHW1605M0TN	H breakerless				●			●				Fig. 17	ARB5○○○R-○
RDMT1605M0TN	M with breaker	●		●	●			●					
RDMT1605M0EN													

*Secondary recommended work material for RDMW0501M0EN: JP4105 and RDMW0702M0EN: JP4105 are P (steel) and K (FC, FCD).

[Note] Please note that the JS Coating does not cause a reaction in conductive touch sensors.

Line Up

The Shanks for Modular Mill

Carbide Shank

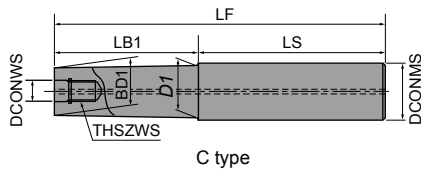

C type

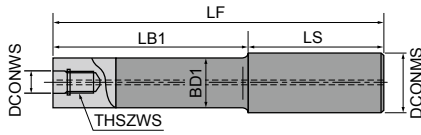

E type

Steel Shank

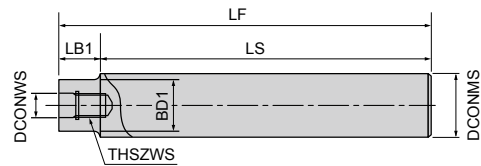

B type

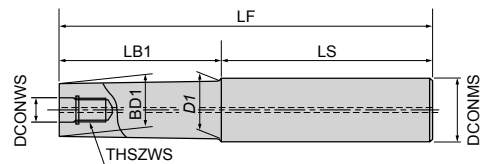

C type (Tapered neck)

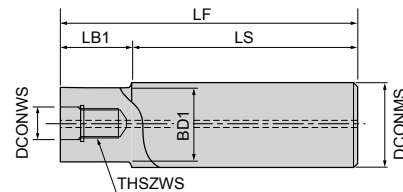

D type

Item code	Stock	Size (mm)								Type	Cutter body	With/without air hole	
		DCONWS	THSZWS	LF	LB1	LS	BD1	DCONMS	D1				
ASC12-6.5-74-24Z	●	6.5	M6	74	24	50	11	12	11.5	C	φ12	-	
ASC12-6.5-94-44Z	●			94	44	50							
ASC12-6.5-129-64Z	●			129	64	65							
ASC12-6.5-129-24Z	●			129	24	105							
ASC16-8.5-95-30Z	●	8.5	M8	95	30	65	14.5	16	15.5	C	φ16	○	
ASC16-8.5-120-55Z	●			120	55	65							
ASC16-8.5-140-75Z	●			140	75	65							
ASC16-8.5-160-95Z	●			160	95	65							
ASC16-8.5-160-30Z	●			160	30	130							
※2 ASC20-10.5-120-50Z	●	10.5	M10	120	50	70	18.5	20	19.5	C	φ20 φ22	○	
※2 ASC20-10.5-170-90Z	●			170	90	80							
※2 ASC20-10.5-220-120Z	●			220	120	100							
※2 ASC20-10.5-270-150Z	●			270	150	120							
※2 ASC20-10.5-220-50Z	●	10.5	M10	220	50	170	18.5	20	19.5	C	φ20 φ22	○	
※2 ASC20-10.5-270-50Z	●			270									220
※2 ASC25-12.5-145-65	●	12.5	M12	145	65	80	23	25	-	E	φ25 φ28	○	
※2 ASC25-12.5-215-115	●			215	115	100							
※2 ASC25-12.5-265-145	●			265	145	120							
※2 ASC25-12.5-315-195	●			315	195	120							
※2 ASC25-12.5-265-65	●	12.5	M12	265	65	200	23	25	-	E	φ25 φ28	○	
※2 ASC25-12.5-315-65	●			315									250
ASC32-17-160-80	●	17	M16	160	80	80	28	32	-	E	φ30 φ32 (φ40)	○	
ASC32-17-210-110	●			210	110	100							
ASC32-17-260-140	●			260	140	120							
ASC32-17-310-190	●			310	190	120							
ASC32-17-360-240	●			360	240	120							
ASC32-17-260-80	●	17	M16	260	80	180	28	32	-	E	φ30 φ32 (φ40)	○	
ASC32-17-310-80	●			310									230
ASC32-17-360-80	●			360									280

- [Note] ① When ※2 and ※1 (P5) are used together as a set, there is no interference.
 ② Commercial milling chucks or shrink-fit holders can be used.
 ③ For the φ40 size, it is recommended that the protrusion length be 200mm or less.

Item code	Stock	Size (mm)								Type	Cutter body	With/without air hole
		DCONWS	THSZWS	LF	LB1	LS	BD1	DCONMS	D1			
AS12-6.5-84-4	●	6.5	M6	84	4	80	11	12	-	B	φ12	-
AS16-8.5-95-15	●	8.5	M8	95	15	80	14.5	16	15.5	C	φ16	○
AS20-10.5-100-20	●	10.5	M10	100	20	80	18	20	-	D	φ20 φ22	○
AS25-12.5-115-35	●	12.5	M12	115	35	80	23	25	-	D	φ25 φ28	○
AS32-17-110-30	●	17	M16	110	30	80	28	32	-	D	φ30 φ32 φ40	○

[Note] Commercial milling chucks can be used.

Steel Shank

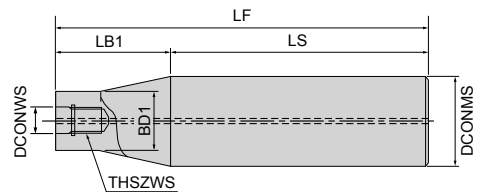

※ For neck section or total length, additional machining to user specifications is possible.

Item code	Stock	Size (mm)								Cutter body	With/without air hole
		DCONWS	THSZWS	LF	LB1	LS	BD1	DCONMS	D1		
AS42-17-360-90	●	17	M16	360	90	270	28	42	-	φ30 φ32 φ40	○

[Note] Commercial milling chucks can be used.

Modular Mill Arbor

HSK

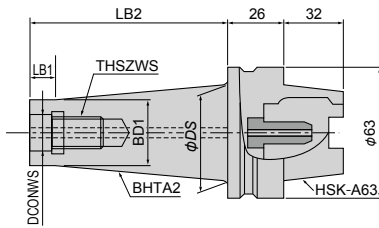

Item code	Stock	Size (mm)							With/ without air hole
		DCONWS	THSZWS	BD1	φDS	LB2	LB1	BHTA2	
HSK-A63-10.5-30-18	●	10.5	M10	18	20.8	30	-	3°	○
HSK-A63-10.5-70-18	●				25	70	10	3°	
HSK-A63-10.5-70-18S	●				48	70	10	12°	
HSK-A63-10.5-120-18	●	30.2	120	10	3°				
HSK-A63-12.5-35-21	●	12.5	M12	21	24.3	35	-	3°	
HSK-A63-12.5-65-21	●				27.5	65	10	3°	
HSK-A63-12.5-65-21S	●				48	65	10	12°	
HSK-A63-12.5-115-21	●	32.7	115	10	3°				
HSK-A63-17-40-28	●	17	M16	28	31.8	40	-	3°	
HSK-A63-17-60-28	●				33.9	60	10	3°	
HSK-A63-17-60-28S	●				48	60	10	9.5°	
HSK-A63-17-110-28	●				39.2	110	10	3°	

[Note] Coolant Pipe is attached.

BT30

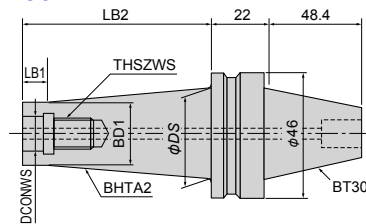

※For neck section, additional machining to user specifications is possible.

Item code	Stock	Size (mm)							With/ without air hole
		DCONWS	THSZWS	BD1	φDS	LB2	LB1	BHTA2	
BT30-6.5-30-9.7		6.5	M6	9.7	25	30	5	17°	-
BT30-6.5-55-9.7						55	10	9.6°	
BT30-6.5-80-9.7						80	10	6.2°	
BT30-8.5-25-15		8.5	M8	15	30	25	5	20.6°	
BT30-8.5-50-15						50	10	10.6°	
BT30-8.5-75-15						75	10	6.6°	
BT30-10.5-20-18		10.5	M10	18	35	20	5	29.5°	
BT30-10.5-45-18						45	10	13.7°	
BT30-10.5-70-18						70	10	8.1°	
BT30-12.5-15-21		12.5	M12	21	40	15	5	32.3°	
BT30-12.5-40-21						40	10	17.6°	
BT30-12.5-65-21						65	10	9.8°	
BT30-12.5-85-21						85	10	7.2°	
BT30-17-10-28		17	M16	28	40	10	5	31°	
BT30-17-35-28						35	10	13.5°	
BT30-17-60-28						60	10	6.8°	

[Note] When using the BT30 arbor for modular mills, determine the processing conditions using the standard cutting conditions table as a general guide. If vibrations are a concern due to the processing conditions, adjust conditions by 1.reducing cutting depth (ap) or 2.reducing per-flute feed rate (fz).

Bore Type Arbor

Arbor

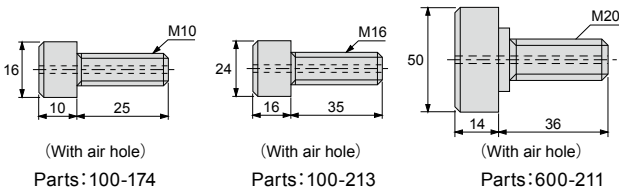
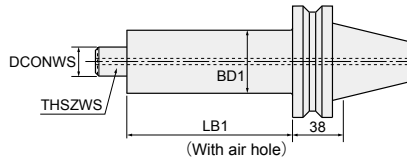

Item code	Stock	Size (mm)				Weight (kgf)	Arbor screw	Cutter body
		DCONWS	THSZWS	LB1	BD1			
BT50-22.225-50-50	●	22.225	M10	50	47	4.3	100-174	ARB4050R-3 ARB4050R-5
BT50-22.225-100-50	●			100		5.0		
BT50-22.225-150-50	●			150		5.7		
BT50-22.225-200-50	●			200		6.4		
BT50-22.225-250-50	●	250	7.1					
BT50-22.225-50-63	●	22.225	M10	50	60	4.8	100-174	ARB4063R-4 ARB4063R-6
BT50-22.225-100-63	●			100		5.9		
BT50-22.225-150-63	●			150		7.0		
BT50-22.225-200-63	●			200		8.1		
BT50-22.225-250-63	●			250		9.3		
BT50-22.225-350-63	●	350	11.5					
BT50-31.75-80-80	●	31.75	M16	80	76	6.8	100-213	ARB4080R-4 ARB4080R-6
BT50-31.75-130-80	●			130		8.5		
BT50-31.75-180-80	●			180		10.2		
BT50-31.75-260-80	●			260		12.9		
BT50-31.75-330-80	●			330		15.4		
BT50-31.75-80-100	●	31.75	M16	80	96	8.3	100-213	ARB4100R-5 ARB5100R-5
BT50-31.75-130-100	●			130		11.1		
BT50-31.75-180-100	●			180		13.9		
BT50-31.75-260-100	●			260		18.4		
BT50-31.75-330-100	●	330	22.4					
BT50-38.1-180-125	●	38.1	M20	180	98	14.8	600-211	ARB4125R-6 ARB5125R-6
BT50-38.1-260-125	●			260		19.7		
BT50-38.1-330-125	●			330		24.0		

[Note] Arbor screw is attached on an arbor. Screws for cutters as lours are not equipped with cutter bodies.

BT40

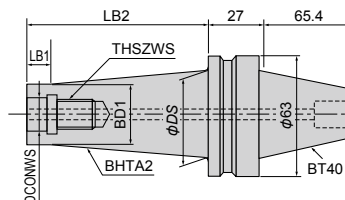

※For neck section, additional machining to user specifications is possible.

Item code	Stock	Size (mm)							With/ without air hole
		DCONWS	THSZWS	BD1	φDS	LB2	LB1	BHTA2	
BT40-6.5-30-9.7		6.5	M6	9.7	25	30	5	17°	-
BT40-6.5-55-9.7						55	10	9.6°	
BT40-6.5-80-9.7						80	10	6.2°	
BT40-6.5-130-9.7		130	10	3.6°					
BT40-8.5-25-15		8.5	M8	15	30	25	5	20.6°	
BT40-8.5-50-15						50	10	10.6°	
BT40-8.5-75-15						75	10	6.6°	
BT40-8.5-125-15		125	10	3.7°					
BT40-10.5-20-18		10.5	M10	18	35	20	5	29.5°	
BT40-10.5-45-18						45	10	13.7°	
BT40-10.5-70-18						70	10	8.1°	
BT40-10.5-120-18		120	10	4.4°					
BT40-12.5-15-21		12.5	M12	21	40	15	5	32.3°	
BT40-12.5-40-21						40	10	17.6°	
BT40-12.5-65-21						65	10	9.8°	
BT40-12.5-115-21						115	10	5.2°	
BT40-17-10-28		17	M16	28	48	10	5	45°	
BT40-17-35-28						35	10	21.8°	
BT40-17-60-28						60	10	11.3°	
BT40-17-110-28		110	10	5.7°					

Item code	Stock	Size(mm)										Weight (kg)	Rigidity value (μm) δ ↓	
		G	φD	H	H ₁	φC	L	M	L ₁	φC ₁	φC ₂			
A63-RSG8-130-M50							130		80				1.3	1.5
A63-RSG8-160-M50							160	50	110				1.4	1.7
A63-RSG8-190-M50							190		140				1.9	1.7
A63-RSG8-155-M75							155		80				1.4	3.1
A63-RSG8-185-M75							185	75	110				1.5	3.4
A63-RSG8-215-M75		M8	8.5	18	6.5	15	215		140		30	32	2.0	3.4
A63-RSG8-170-M90							170		80				2.0	4.4
A63-RSG8-200-M90							200	90	110				1.5	4.8
A63-RSG8-230-M90							230		140				2.0	4.9
A63-RSG8-185-M105							185		80				1.5	6.2
A63-RSG8-215-M105							215	105	110				1.6	6.6
A63-RSG8-245-M105							245		140				2.1	6.7
A63-RSG10-125-M25							125		100				1.6	0.4
A63-RSG10-155-M25							155	25	130				1.9	0.5
A63-RSG10-185-M25							185		160				2.3	0.6
A63-RSG10-150-M50							150		100				1.7	0.8
A63-RSG10-180-M50							180	50	130				2.0	1.0
A63-RSG10-210-M50							210		160				2.4	1.2
A63-RSG10-175-M75							175		100				1.8	1.6
A63-RSG10-205-M75							205	75	130				2.1	1.8
A63-RSG10-235-M75							235		160				2.5	2.0
A63-RSG10-200-M100		M10	10.5	22	6.5	19	200		100		36	38	1.8	2.7
A63-RSG10-230-M100							230	100	130				2.1	2.9
A63-RSG10-260-M100							260		160				2.5	3.2
A63-RSG10-220-M120							220		100				1.9	4.0
A63-RSG10-250-M120							250	120	130				2.2	4.2
A63-RSG10-280-M120							280		160				2.6	4.5
A63-RSG10-240-M140							240		100				2.0	5.6
A63-RSG10-270-M140							270	140	130				2.3	5.9
A63-RSG10-300-M140							300		160				2.7	6.2
A63-RSG12-125-M25							125		100				1.9	0.3
A63-RSG12-155-M25							155	25	130				2.3	0.4
A63-RSG12-185-M25							185		160				2.7	0.5
A63-RSG12-150-M50							150		100				2.0	0.5
A63-RSG12-180-M50							180	50	130				2.4	0.6
A63-RSG12-210-M50							210		160				2.8	0.8
A63-RSG12-175-M75							175		100				2.2	0.9
A63-RSG12-205-M75							205	75	130				2.6	1.0
A63-RSG12-235-M75							235		160				3.0	1.3
A63-RSG12-200-M100		M12	12.5	22	6	24	200		100		43	45	2.3	1.4
A63-RSG12-230-M100							230	100	130				2.7	1.6
A63-RSG12-260-M100							260		160				3.1	1.9
A63-RSG12-225-M125							225		100				2.5	2.1
A63-RSG12-255-M125							255	125	130				2.9	2.4
A63-RSG12-285-M125							285		160				3.3	2.7
A63-RSG12-250-M150							250		100				2.6	3.1
A63-RSG12-280-M150							280	150	130				3.0	3.4
A63-RSG12-310-M150							310		160				3.4	3.8
A63-RSG16-140-M25							140	25					2.8	0.2
A63-RSG16-165-M50							165	50					3.2	0.4
A63-RSG16-190-M75							190	75					3.6	0.6
A63-RSG16-215-M100		M16	17	25	6	29	215	100	115	52	54		2.8	0.9
A63-RSG16-240-M125 ※							240	125					2.8	1.3
A63-RSG16-265-M150 ※							265	150					3.2	1.9
A63-RSG16-290-M175 ※							290	175					3.6	2.5
A100-RSG8-120-M25							120		95				2.6	0.6
A100-RSG8-150-M25							150	25	125				2.9	0.8
A100-RSG8-180-M25							180		155				3.4	0.8
A100-RSG8-145-M50							145		95				2.6	1.5
A100-RSG8-175-M50							175	50	125				2.9	1.7
A100-RSG8-205-M50							205		155				3.4	1.7
A100-RSG8-170-M75		M8	8.5	18	6.5	15	170		95		30	32	2.7	3.1
A100-RSG8-200-M75							200	75	125				3.0	3.4
A100-RSG8-230-M75							230		155				3.5	3.4
A100-RSG8-185-M90							185		95				2.7	4.5
A100-RSG8-215-M90							215	90	125				3.0	4.9
A100-RSG8-245-M90							245		155				3.5	4.8
A100-RSG8-200-M105							200	105	95				2.8	6.3

Item code	Stock	Size(mm)										Weight (kg)	Rigidity value (μm) δ ↓		
		G	φD	H	H ₁	φC	L	M	L ₁	φC ₁	φC ₂				
A100-RSG8-230-M105															
A100-RSG8-260-M105		M8	8.5	18	6.5	15	230		105	125		30	32	3.1	6.7
A100-RSG10-140-M25							140		115					3.1	0.4
A100-RSG10-170-M25							170	25	145					3.5	0.5
A100-RSG10-200-M25							200		175					4.4	0.5
A100-RSG10-165-M50							165		115					3.2	0.8
A100-RSG10-195-M50							195	50	145					3.6	1.0
A100-RSG10-225-M50							225		175					4.5	1.0
A100-RSG10-190-M75							190		115					3.3	1.6
A100-RSG10-220-M75							220	75	145					3.7	1.8
A100-RSG10-250-M75							250		175					4.6	1.8
A100-RSG10-215-M100		M10	10.5	22	6.5	19	215		115		36	38		3.3	2.7
A100-RSG10-245-M100							245	100	145					3.7	2.9
A100-RSG10-275-M100							275		175					4.6	2.9
A100-RSG10-235-M120							235		115					3.4	4.0
A100-RSG10-265-M120							265	120	145					3.8	4.2
A100-RSG10-295-M120							295		175					4.7	4.2
A100-RSG10-255-M140							255		115					3.5	5.6
A100-RSG10-285-M140							285	140	145					3.9	5.8
A100-RSG10-315-M140							315		175					4.8	5.8
A100-RSG12-140-M25							140		115					3.4	0.3
A100-RSG12-170-M25							170	25	145					3.7	0.4
A100-RSG12-200-M25							200		175					4.7	0.4
A100-RSG12-165-M50							165		115					3.5	0.5
A100-RSG12-195-M50							195	50	145					3.8	0.6
A100-RSG12-225-M50							225		175					4.8	0.6
A100-RSG12-190-M75							190		115					3.7	0.8
A100-RSG12-220-M75							220	75	145					4.0	1.0
A100-RSG12-250-M75							250		175					5.0	1.0
A100-RSG12-215-M100		M12	12.5	22	6	24	215		115					3.8	1.4
A100-RSG12-245-M100							245	100	145		43	45		4.1	1.6
A100-RSG12-275-M100							275		175					5.1	1.6
A100-RSG12-240-M125							240		115					4.0	2.1
A100-RSG12-270-M125							270	125	145					4.3	2.4
A100-RSG12-300-M125							300		175					5.3	2.4
A100-RSG12-265-M150							265		115					4.1	3.0
A100-RSG12-295-M150							295	150	145					4.4	3.4
A100-RSG12-325-M150							325		175					5.4	3.4
A100-RSG12-320-M175							290		115					4.3	4.3
A100-RSG12-320-M175							320	175	145					4.6	4.6
A100-RSG12-350-M175							350		175					5.6	4.6
A100-RSG16-140-M25							140		115					4.0	0.2
A100-RSG16-170-M25							170	25	145					4.5	0.2
A100-RSG16-200-M25							200		175					5.7	0.2
A100-RSG16-165-M50							165		115					4.2	0.3
A100-RSG16-195-M50							195	50	145					4.7	0.4
A100-RSG16-225-M50							225		175					5.9	0.4
A100-RSG16-190-M75							190		115					4.5	0.5
A100-RSG16-220-M75							220	75	145					5.0	0.6
A100-RSG16-250-M75							250		175					6.1	0.6
A100-RSG16-215-M100							215		115					4.7	0.8
A100-RSG16-245-M100							245	100							

Recommended Cutting Conditions

ARS Regular	ARL Long	ARE Extra Long
-----------------------	--------------------	--------------------------

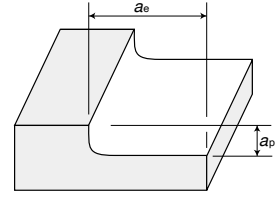

※Red indicates primary recommended grade.

Work material	Recommended grade	Cutting speed m/min	Spindle of machine	Feed rate mm/t	φ20 (2 Flutes r4)			φ25 (2 Flutes r5)			φ32 (3 Flutes r5)		
					Revolution min ⁻¹	Feed speed mm/min	Q cm ³ /min	Revolution min ⁻¹	Feed speed mm/min	Q cm ³ /min	Revolution min ⁻¹	Feed speed mm/min	Q cm ³ /min
Mild steels (200HB or less)	※ JS4060 JS4045	150~ 250	BT40	0.3~ 0.8	3,980	3,180	28.6	3,180	2,540	28.6	2,490	2,990	43.1
					vc=250m/min fz=0.4mm/t ap=1.5mm ae=0.3DCX								
			BT50		3,980	3,180	47.7	3,180	2,540	47.6	2,490	2,990	71.8
					vc=250m/min fz=0.4mm/t ap=1.5mm ae=0.5DCX								
Carbon & Alloy steels (30HRC or less)	JS4060 JS4045	120~ 230	BT40	0.3~ 0.8	3,180	2,540	22.9	2,550	2,040	23	1,990	2,390	34.4
					vc=200m/min fz=0.4mm/t ap=1.5mm ae=0.3DCX								
			BT50		3,180	2,540	38.1	2,550	2,040	38.3	1,990	2,390	57.4
					vc=200m/min fz=0.4mm/t ap=1.5mm ae=0.5DCX								
Carbon & Alloy steels (30~40HRC)	JS4060 JS4045	100~ 200	BT40	0.2~ 0.6	2,390	960	8.6	1,910	760	8.6	1,490	890	12.8
					vc=150m/min fz=0.2mm/t ap=1.5mm ae=0.3DCX								
			BT50		2,390	1,430	21.5	1,910	1,150	21.6	1,490	1,340	32.2
					vc=150m/min fz=0.3mm/t ap=1.5mm ae=0.5DCX								
Carbon & Alloy steels (40~45HRC)	JP4120 JS4045	60~ 150	BT40	0.15~ 0.3	1,590	480	2.9	1,270	380	2.9	990	450	4.3
					vc=100m/min fz=0.15mm/t ap=1mm ae=0.3DCX								
			BT50		1,590	640	6.4	1,270	510	6.4	990	590	9.4
					vc=100m/min fz=0.2mm/t ap=1mm ae=0.5DCX								
Stainless steels SUS	JM4160	150~ 240	BT40	0.2~ 0.8	3,180	1,590	14.3	2,550	1,280	14.4	1,990	1,490	21.5
					vc=200m/min fz=0.25mm/t ap=1.5mm ae=0.3DCX								
			BT50		2,860	1,716	25.7	2,290	1,370	25.7	1,790	1,610	38.6
					vc=180m/min fz=0.3mm/t ap=1.5mm ae=0.5DCX								
Cast irons FC, FCD	JP4120	100~ 220	BT40	0.3~ 1.0	2,860	2,290	20.6	2,290	1,830	20.6	1,790	2,150	31
					vc=180m/min fz=0.4mm/t ap=1.5mm ae=0.3DCX								
			BT50		2,860	2,860	42.9	2,290	2,290	42.9	1,790	2,690	64.6
					vc=180m/min fz=0.5mm/t ap=1.5mm ae=0.5DCX								
Hardened steels (45~50HRC)	JP4120 JP4105	60~ 100	BT40	0.15~ 0.3	1,270	380	2.3	1,020	310	2.3	800	360	3.5
					vc=80m/min fz=0.15mm/t ap=1mm ae=0.3DCX								
			BT50		1,270	380	3.8	1,020	310	3.9	800	360	5.8
					vc=80m/min fz=0.15mm/t ap=1mm ae=0.5DCX								
Hardened steels (50~60HRC)	※1 JP4105 JP4120	50~ 100	BT40	0.05~ 0.2	1,110	220	1.3	890	170	1.2	690	200	1.9
					vc=70m/min fz=0.1mm/t ap=1mm ae=0.3DCX								
			BT50		1,110	220	2.2	890	170	2.1	690	200	3.2
					vc=70m/min fz=0.1mm/t ap=1mm ae=0.5DCX								

※1: [JP4105] insert's grade specialized in High hardened steel is not suitable for Non-heat-treated steel material.

※2: [JS4060][JM4160] is recommended under heavy interrupt cutting.

[Note]

- Please note that the JS Coating does not cause a reaction in conductive touch sensors.
- Due to fire risks do not use neat cutting oil as a coolant.
- The evacuation of swarf can cause burns, cuts or damage to the eyes please ensure the correct safety cover is fitted around the machine, and necessary personal protection equipment is worn by the machine operator.
- These conditions are for general guidance; in actual machining conditions adjust the parameters according to your actual machine and work-piece conditions.
- If vibrations are a concern due to the cutting conditions, adjust conditions by
1. reducing cutting depth (ap) or 2. reducing per-flute feed rate (fz).
- In the case of slotting, feed speed could be down to 70% of the whole.
- In steel exceeding 60HRC, such as dice steel between the colds, please set the sending (fz) value per one edge about to 1/2.
- This table is based on the overhang of regular type (L1).

	φ40 (3 Flutes r6)			φ50 (4 Flutes r6)			φ40 (2 Flutes r8)			φ50 (3 Flutes r8)			φ63 (3 Flutes r8)			Work material
	Revolution min ⁻¹	Feed speed mm/min	Q cm ³ /min	Revolution min ⁻¹	Feed speed mm/min	Q cm ³ /min	Revolution min ⁻¹	Feed speed mm/min	Q cm ³ /min	Revolution min ⁻¹	Feed speed mm/min	Q cm ³ /min	Revolution min ⁻¹	Feed speed mm/min	Q cm ³ /min	
	1,990	2,990	71.8	1,590	3,180	95.4	1,990	1,990	47.8	1,590	2,390	71.7	1,260	1,890	71.4	Mild steels (200HB or less)
	v _c =250m/min f _z =0.5mm/t a _p =2mm a _e =0.3DCX			v _c =250m/min f _z =0.5mm/t a _p =2mm a _e =0.3DCX			v _c =250m/min f _z =0.5mm/t a _p =2mm a _e =0.3DCX			v _c =250m/min f _z =0.5mm/t a _p =2mm a _e =0.3DCX			v _c =250m/min f _z =0.5mm/t a _p =2mm a _e =0.3DCX			
	1,990	4,780	191.2	1,590	5,090	254.5	1,990	3,180	159	1,590	3,820	238.8	1,260	3,020	237.8	
	v _c =250m/min f _z =0.8mm/t a _p =2mm a _e =0.5DCX			v _c =250m/min f _z =0.8mm/t a _p =2mm a _e =0.5DCX			v _c =250m/min f _z =0.8mm/t a _p =2.5mm a _e =0.5DCX			v _c =250m/min f _z =0.8mm/t a _p =2.5mm a _e =0.5DCX			v _c =250m/min f _z =0.8mm/t a _p =2.5mm a _e =0.5DCX			
	1,590	1,910	45.8	1,270	2,030	60.9	1,590	1,270	30.5	1,270	1,520	45.6	1,010	1,210	45.7	Carbon & Alloy steels (30HRC or less)
	v _c =200m/min f _z =0.4mm/t a _p =2mm a _e =0.3DCX			v _c =200m/min f _z =0.4mm/t a _p =2mm a _e =0.3DCX			v _c =200m/min f _z =0.4mm/t a _p =2mm a _e =0.3DCX			v _c =200m/min f _z =0.4mm/t a _p =2mm a _e =0.3DCX			v _c =200m/min f _z =0.4mm/t a _p =2mm a _e =0.3DCX			
	1,590	2,860	114.4	1,270	3,050	152.5	1,590	1,910	95.5	1,270	2,290	143.1	1,010	2,120	167	
	v _c =200m/min f _z =0.6mm/t a _p =2mm a _e =0.5DCX			v _c =200m/min f _z =0.6mm/t a _p =2mm a _e =0.5DCX			v _c =200m/min f _z =0.6mm/t a _p =2.5mm a _e =0.5DCX			v _c =200m/min f _z =0.6mm/t a _p =2.5mm a _e =0.5DCX			v _c =200m/min f _z =0.7mm/t a _p =2.5mm a _e =0.5DCX			
	1,190	710	17	960	770	23.1	1,190	480	11.5	960	580	17.4	760	460	17.4	Carbon & Alloy steels (30~40HRC)
	v _c =150m/min f _z =0.2mm/t a _p =2mm a _e =0.3DCX			v _c =150m/min f _z =0.2mm/t a _p =2mm a _e =0.3DCX			v _c =150m/min f _z =0.2mm/t a _p =2mm a _e =0.3DCX			v _c =150m/min f _z =0.2mm/t a _p =2mm a _e =0.3DCX			v _c =150m/min f _z =0.2mm/t a _p =2mm a _e =0.3DCX			
	1,190	1,070	42.8	960	1,150	57.5	1,190	950	47.5	960	1,150	71.9	760	910	71.7	
	v _c =150m/min f _z =0.3mm/t a _p =2mm a _e =0.5DCX			v _c =150m/min f _z =0.4mm/t a _p =2mm a _e =0.5DCX			v _c =150m/min f _z =0.4mm/t a _p =2.5mm a _e =0.5DCX			v _c =150m/min f _z =0.4mm/t a _p =2.5mm a _e =0.5DCX			v _c =150m/min f _z =0.4mm/t a _p =2.5mm a _e =0.5DCX			
	800	360	6.5	640	380	8.6	800	240	4.3	640	290	6.5	510	230	6.5	Carbon & Alloy steels (40~45HRC)
	v _c =100m/min f _z =0.15mm/t a _p =1.5mm a _e =0.3DCX			v _c =100m/min f _z =0.15mm/t a _p =1.5mm a _e =0.3DCX			v _c =100m/min f _z =0.15mm/t a _p =1.5mm a _e =0.3DCX			v _c =100m/min f _z =0.15mm/t a _p =1.5mm a _e =0.3DCX			v _c =100m/min f _z =0.15mm/t a _p =1.5mm a _e =0.3DCX			
	800	480	14.4	640	510	19.1	800	320	12.8	640	380	19	510	310	19.5	
	v _c =100m/min f _z =0.2mm/t a _p =1.5mm a _e =0.5DCX			v _c =100m/min f _z =0.2mm/t a _p =2mm a _e =0.5DCX			v _c =100m/min f _z =0.2mm/t a _p =2mm a _e =0.5DCX			v _c =100m/min f _z =0.2mm/t a _p =2mm a _e =0.5DCX			v _c =100m/min f _z =0.2mm/t a _p =2mm a _e =0.5DCX			
	1,590	1,430	34.3	1,270	1,520	45.6	1,590	950	22.8	1,270	1,140	34.2	1,010	910	34.4	Stainless steels SUS
	v _c =200m/min f _z =0.3mm/t a _p =2mm a _e =0.3DCX			v _c =200m/min f _z =0.3mm/t a _p =2mm a _e =0.3DCX			v _c =200m/min f _z =0.3mm/t a _p =2mm a _e =0.3DCX			v _c =200m/min f _z =0.3mm/t a _p =2mm a _e =0.3DCX			v _c =200m/min f _z =0.3mm/t a _p =2mm a _e =0.3DCX			
	1,430	2,150	86	1,150	2,300	115	1,430	1,720	86	1,150	2,070	129.4	910	1,640	129.2	
	v _c =180m/min f _z =0.5mm/t a _p =2mm a _e =0.5DCX			v _c =180m/min f _z =0.6mm/t a _p =2mm a _e =0.5DCX			v _c =180m/min f _z =0.6mm/t a _p =2.5mm a _e =0.5DCX			v _c =180m/min f _z =0.6mm/t a _p =2.5mm a _e =0.5DCX			v _c =180m/min f _z =0.6mm/t a _p =2.5mm a _e =0.5DCX			
	1,430	2,150	51.6	1,150	2,300	69	1,430	1,430	34.3	1,150	1,730	51.9	910	1,370	51.8	Cast irons FC, FCD
	v _c =180m/min f _z =0.5mm/t a _p =2mm a _e =0.3DCX			v _c =180m/min f _z =0.5mm/t a _p =2mm a _e =0.3DCX			v _c =180m/min f _z =0.5mm/t a _p =2mm a _e =0.3DCX			v _c =180m/min f _z =0.5mm/t a _p =2mm a _e =0.3DCX			v _c =180m/min f _z =0.5mm/t a _p =2mm a _e =0.3DCX			
	1,430	3,430	137.2	1,150	3,680	184	1,430	2,290	114.5	1,150	2,760	172.5	910	2,180	171.7	
	v _c =180m/min f _z =0.8mm/t a _p =2mm a _e =0.5DCX			v _c =180m/min f _z =0.8mm/t a _p =2mm a _e =0.5DCX			v _c =180m/min f _z =0.8mm/t a _p =2.5mm a _e =0.5DCX			v _c =180m/min f _z =0.8mm/t a _p =2.5mm a _e =0.5DCX			v _c =180m/min f _z =0.8mm/t a _p =2.5mm a _e =0.5DCX			
	640	290	3.5	510	310	4.7	640	220	4	510	260	5.9	400	200	5.7	Hardened steels (45~50HRC)
	v _c =80m/min f _z =0.15mm/t a _p =1mm a _e =0.3DCX			v _c =80m/min f _z =0.17mm/t a _p =1.5mm a _e =0.3DCX			v _c =80m/min f _z =0.17mm/t a _p =1.5mm a _e =0.3DCX			v _c =80m/min f _z =0.17mm/t a _p =1.5mm a _e =0.3DCX			v _c =80m/min f _z =0.17mm/t a _p =1.5mm a _e =0.3DCX			
	640	330	6.6	510	350	8.8	640	260	7.8	510	310	11.6	400	240	11.3	
	v _c =80m/min f _z =0.17mm/t a _p =1mm a _e =0.5DCX			v _c =80m/min f _z =0.2mm/t a _p =1.5mm a _e =0.5DCX			v _c =80m/min f _z =0.2mm/t a _p =1.5mm a _e =0.5DCX			v _c =80m/min f _z =0.2mm/t a _p =1.5mm a _e =0.5DCX			v _c =80m/min f _z =0.2mm/t a _p =1.5mm a _e =0.5DCX			
	550	160	1.9	440	170	2.5	550	110	1.3	440	130	1.9	350	100	1.9	Hardened steels (50~60HRC)
	v _c =70m/min f _z =0.1mm/t a _p =1mm a _e =0.3DCX			v _c =70m/min f _z =0.1mm/t a _p =1mm a _e =0.3DCX			v _c =70m/min f _z =0.1mm/t a _p =1mm a _e =0.3DCX			v _c =70m/min f _z =0.1mm/t a _p =1mm a _e =0.3DCX			v _c =70m/min f _z =0.1mm/t a _p =1mm a _e =0.3DCX			
	550	160	3.2	440	170	4.2	550	110	2.2	440	130	3.2	350	100	3.1	
	v _c =70m/min f _z =0.1mm/t a _p =1mm a _e =0.5DCX			v _c =70m/min f _z =0.1mm/t a _p =1mm a _e =0.5DCX			v _c =70m/min f _z =0.1mm/t a _p =1mm a _e =0.5DCX			v _c =70m/min f _z =0.1mm/t a _p =1mm a _e =0.5DCX			v _c =70m/min f _z =0.1mm/t a _p =1mm a _e =0.5DCX			

Ramping, Helical Milling, Feeding toward Z-AXIS

There are restrictions to ramp angle (θ) and cutting depth (a_p) toward Z-axis because of designs of cutting edge.

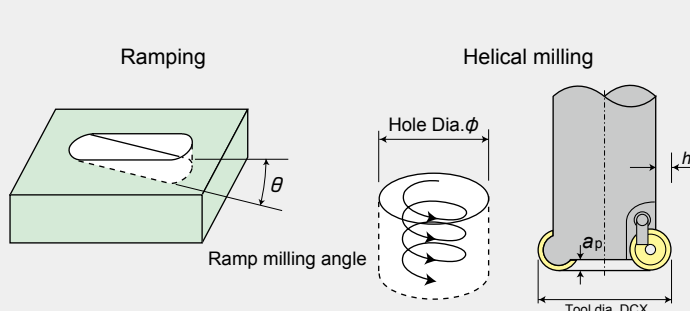

	(mm)					
Tool dia. DCX	φ20(r4)	φ25(r5)	φ32(r5)	φ40(r6)	φ50(r8)	φ63(r8)
Recommended θ	Below 3 degrees					
h	1	2	2	2.5	2.5	2.5
a_p	2	3	3	3.7	4.5	5.5
Hole Dia.	28~38	34~48	48~62	60~78	75~98	101~124

[Note] Due to swarf evacuation wear safety glasses in the vicinity of the operation.

Recommended Cutting Conditions

ARB Bore type
AR Bore type

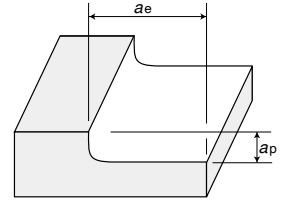

※Red indicates primary recommended grade.

Work material	Recommended grade	Cutting speed m/min	Spindle of machine	Feed rate mm/t	φ40 (3 Flutes r6)			φ50 (5 Flutes r6)			φ63 (6 Flutes r6)			φ80 (6 Flutes r6)		
					Revolution min ⁻¹	Feed speed mm/min	Q cm ³ /min	Revolution min ⁻¹	Feed speed mm/min	Q cm ³ /min	Revolution min ⁻¹	Feed speed mm/min	Q cm ³ /min	Revolution min ⁻¹	Feed speed mm/min	Q cm ³ /min
Mild steels (200HB or less)	※ JS4060 JS4045	150~ 250	BT40	0.3~ 0.8	1,990	2,990	71.8	1,590	3,975	95.4	1,260	3,780	142.9	—	—	—
			vc=250m/min fz=0.5mm/t ap=2mm ae=0.3DCX													
		BT50	1,990	4,780	191.2	1,590	6,360	254.5	1,260	6,050	381.2	1,000	4,800	384		
vc=250m/min fz=0.8mm/t ap=2mm ae=0.5DCX																
Carbon & Alloy steels (30HRC or less)	JS4060 JS4045	120~ 230	BT40	0.3~ 0.8	1,590	1,910	45.8	1,270	2,540	60.9	1,010	2,420	91.5	—	—	—
			vc=200m/min fz=0.4mm/t ap=2mm ae=0.3DCX													
		BT50	1,590	2,860	114.4	1,270	3,810	152.5	1,010	3,640	229.3	800	2,880	230.4		
vc=200m/min fz=0.6mm/t ap=2mm ae=0.5DCX																
Carbon & Alloy steels (30~40HRC)	JS4060 JS4045	100~ 200	BT40	0.2~ 0.6	1,190	710	17	960	960	23.1	760	910	34.4	—	—	—
			vc=150m/min fz=0.2mm/t ap=2mm ae=0.3DCX													
		BT50	1,190	1,070	42.8	960	1,440	57.5	760	1,370	86.3	600	1,080	86.4		
vc=150m/min fz=0.3mm/t ap=2mm ae=0.5DCX																
Carbon & Alloy steels (40~45HRC)	JP4120 JS4045	60~ 150	BT40	0.15~ 0.3	800	360	6.5	640	480	8.6	510	460	13	—	—	—
			vc=100m/min fz=0.15mm/t ap=1.5mm ae=0.3DCX													
		BT50	800	480	14.4	640	640	19.1	510	610	28.8	400	480	28.8		
vc=100m/min fz=0.2mm/t ap=1.5mm ae=0.5DCX																
Stainless steels SUS	JM4160	150~ 240	BT40	0.2~ 0.8	1,590	1,430	34.3	1,270	1,905	45.6	1,010	1,820	68.8	—	—	—
			vc=200m/min fz=0.3mm/t ap=2mm ae=0.3DCX													
		BT50	1,430	2,150	86	1,150	2,875	115	910	2,730	172	720	2,160	172.8		
vc=180m/min fz=0.5mm/t ap=2mm ae=0.5DCX																
Cast irons FC, FCD	JP4120	100~ 220	BT40	0.3~ 1.0	1,430	2,150	51.6	1,150	2,875	69	910	2,730	103.2	—	—	—
			vc=180m/min fz=0.5mm/t ap=2mm ae=0.3DCX													
		BT50	1,430	3,430	137.2	1,150	4,600	184	910	4,370	275.3	720	3,460	276.8		
vc=180m/min fz=0.8mm/t ap=2mm ae=0.5DCX																
Hardened steels (45~50HRC)	JP4120 JP4105	60~ 100	BT40	0.15~ 0.3	640	290	3.5	510	383	4.7	400	360	6.8	—	—	—
			vc=80m/min fz=0.15mm/t ap=1mm ae=0.3DCX													
		BT50	640	330	6.6	510	434	8.8	400	410	12.9	320	330	13.2		
vc=80m/min fz=0.17mm/t ap=1mm ae=0.5DCX																
Hardened steels (50~60HRC)	※1 JP4105 JP4120	50~ 100	BT40	0.05~ 0.2	550	160	1.9	440	220	2.5	350	210	3.9	270	160	3.8
			vc=70m/min fz=0.1mm/t ap=1mm ae=0.3DCX													
		BT50	550	160	3.2	440	220	4.2	350	210	6.6	270	160	6.4		
vc=70m/min fz=0.1mm/t ap=1mm ae=0.5DCX																

※1: [JP4105] insert's grade specialized in High hardened steel is not suitable for Non-heat-treated steel material.

※2: [JS4060][JM4160] is recommended under heavy interrupt cutting.

[Note]

- ① Please note that the JS Coating does not cause a reaction in conductive touch sensors.
- ② Due to fire risks do not use neat cutting oil as a coolant.
- ③ The evacuation of swarf can cause burns, cuts or damage to the eyes please ensure the correct safety cover is fitted around the machine, and necessary personal protection equipment is worn by the machine operator.
- ④ These conditions are for general guidance; in actual machining conditions adjust the parameters according to your actual machine and work-piece conditions.
- ⑤ If vibrations are a concern due to the cutting conditions, adjust conditions by
1. reducing cutting depth (ap) or 2. reducing per-flute feed rate (fz).
- ⑥ In the case of slotting, feed speed could be down to 70% of the whole.
- ⑦ In steel exceeding 60HRC, such as dice steel between the colds, please set the sending (fz) value per one edge about to 1/2.

φ100 (5 Flutes r6)			φ63 (3 Flutes r8)			φ80 (4 Flutes r8)			φ100 (5 Flutes r8)			φ125 (6 Flutes r8)			Work material
Revolution min ⁻¹	Feed speed mm/min	Q cm ³ /min	Revolution min ⁻¹	Feed speed mm/min	Q cm ³ /min	Revolution min ⁻¹	Feed speed mm/min	Q cm ³ /min	Revolution min ⁻¹	Feed speed mm/min	Q cm ³ /min	Revolution min ⁻¹	Feed speed mm/min	Q cm ³ /min	
—	—	—	1,260	1,890	71.4	—	—	—	—	—	—	—	—	—	Mild steels (200HB or less)
v _c =250m/min f _z =0.5mm/t a _p =2mm a _e =0.3DCX			v _c =250m/min f _z =0.5mm/t a _p =2mm a _e =0.3DCX												
800	3,200	320	1,260	3,020	237.8	1,000	3,200	320	800	3,200	400	640	3,070	479.7	
v _c =250m/min f _z =0.8mm/t a _p =2mm a _e =0.5DCX			v _c =250m/min f _z =0.8mm/t a _p =2.5mm a _e =0.5DCX												Carbon & Alloy steels (30HRC or less)
—	—	—	1,010	1,210	45.7	—	—	—	—	—	—	—	—	—	
v _c =200m/min f _z =0.4mm/t a _p =2mm a _e =0.3DCX			v _c =200m/min f _z =0.4mm/t a _p =2mm a _e =0.3DCX												
640	1,920	192	1,010	2,120	167	800	2,240	224	640	2,240	280	510	2,140	334.4	Carbon & Alloy steels (30~40HRC)
v _c =200m/min f _z =0.6mm/t a _p =2mm a _e =0.5DCX			v _c =200m/min f _z =0.7mm/t a _p =2.5mm a _e =0.5DCX												
—	—	—	760	460	17.4	—	—	—	—	—	—	—	—	—	
v _c =150m/min f _z =0.2mm/t a _p =2mm a _e =0.3DCX			v _c =150m/min f _z =0.2mm/t a _p =2mm a _e =0.3DCX												Carbon & Alloy steels (40~45HRC)
480	720	72	760	910	71.7	600	960	96	480	960	120	380	910	142.2	
v _c =150m/min f _z =0.3mm/t a _p =2mm a _e =0.5DCX			v _c =150m/min f _z =0.4mm/t a _p =2.5mm a _e =0.5DCX												
—	—	—	510	230	6.5	—	—	—	—	—	—	—	—	—	Carbon & Alloy steels (40~45HRC)
v _c =100m/min f _z =0.15mm/t a _p =1.5mm a _e =0.3DCX			v _c =100m/min f _z =0.15mm/t a _p =1.5mm a _e =0.3DCX												
320	320	24	510	310	19.5	400	320	25.6	320	320	32	250	300	37.5	
v _c =100m/min f _z =0.2mm/t a _p =1.5mm a _e =0.5DCX			v _c =100m/min f _z =0.2mm/t a _p =2mm a _e =0.5DCX												Stainless steels SUS
—	—	—	1,010	910	34.4	—	—	—	—	—	—	—	—	—	
v _c =200m/min f _z =0.3mm/t a _p =2mm a _e =0.3DCX			v _c =200m/min f _z =0.3mm/t a _p =2mm a _e =0.3DCX												
570	1,430	143	910	1,640	129.2	720	1,730	173	570	1,710	213.8	460	1,660	259.4	Cast irons FC, FCD
v _c =180m/min f _z =0.5mm/t a _p =2mm a _e =0.5DCX			v _c =180m/min f _z =0.6mm/t a _p =2.5mm a _e =0.5DCX												
—	—	—	910	1,370	51.8	—	—	—	—	—	—	—	—	—	
v _c =180m/min f _z =0.5mm/t a _p =2mm a _e =0.3DCX			v _c =180m/min f _z =0.5mm/t a _p =2mm a _e =0.3DCX												Hardened steels (45~50HRC)
570	2,280	228	910	2,180	171.7	720	2,300	230	570	2,280	285	460	2,210	345.3	
v _c =180m/min f _z =0.8mm/t a _p =2mm a _e =0.5DCX			v _c =180m/min f _z =0.8mm/t a _p =2.5mm a _e =0.5DCX												
—	—	—	400	200	5.7	—	—	—	—	—	—	—	—	—	Hardened steels (50~60HRC)
v _c =80m/min f _z =0.15mm/t a _p =1mm a _e =0.3DCX			v _c =80m/min f _z =0.17mm/t a _p =1.5mm a _e =0.3DCX												
250	210	10.5	400	240	11.3	320	260	15.6	250	250	18.8	200	240	22.5	
v _c =80m/min f _z =0.17mm/t a _p =1mm a _e =0.5DCX			v _c =80m/min f _z =0.2mm/t a _p =1.5mm a _e =0.5DCX												Hardened steels (50~60HRC)
220	110	3.3	350	100	1.9	—	—	—	—	—	—	—	—	—	
v _c =70m/min f _z =0.1mm/t a _p =1mm a _e =0.3DCX			v _c =70m/min f _z =0.1mm/t a _p =1mm a _e =0.3DCX												
220	110	5.5	350	100	3.1	270	110	4.4	220	110	5.5	170	100	6.2	Hardened steels (50~60HRC)
v _c =70m/min f _z =0.1mm/t a _p =1mm a _e =0.5DCX			v _c =70m/min f _z =0.1mm/t a _p =1mm a _e =0.5DCX												

Ramping, Helical Milling, Feeding toward Z-AXIS

There are restrictions to ramp angle (θ) and cutting depth (a_p) toward Z-axis because of designs of cutting edge.

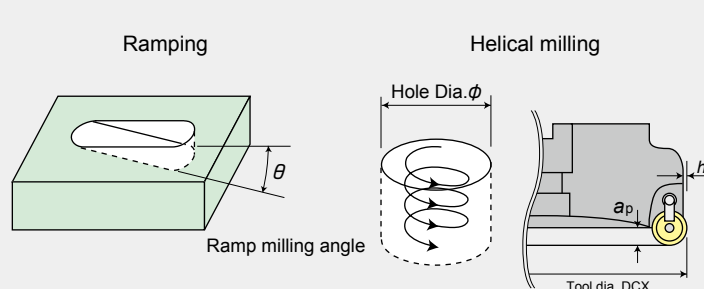

Tool dia. DCX	(mm)					
	φ40(r6)	φ50(r6)	φ63(r8)	φ80(r8)	φ100(r8)	φ125(r8)
Recommended θ	Below 3 degrees					Below 2 degrees
h	2.5	2.5	2.5	2.5	2.5	2.5
a_p	3.7	3.3	5.5	5.5	5.5	5.5
Hole Dia.	60~78	77~100	101~124	135~158	175~198	248~255

[Note] Due to swarf evacuation wear safety glasses in the vicinity of the operation.

Recommended Cutting Conditions

ARM
Modular

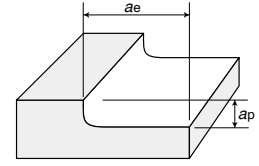

※Red indicates primary recommended grade.

Work material	Recommended grade	Cutting speed Vc m/min	Spindle of machine	Feed rate fz mm/t	φ12 (3 Flutes r2.5)			φ16 (2 Flutes r3.5)		
					Revolution n min ⁻¹	Feed speed Vf mm/min	Chip removal volume cm ³ /min	Revolution n min ⁻¹	Feed speed Vf mm/min	Chip removal volume cm ³ /min
Mild steels (200HB or less)	※ JS4060 JS4045	150~250	BT40	0.1~0.8	6,630	1,990	6	4,970	1,990	16
			BT50		vc=250m/min fz=0.1mm/t ap=0.5mm ae=0.5DCX			vc=250m/min fz=0.2mm/t ap=1mm ae=0.5DCX		
Carbon & Alloy steels (30HRC or less)	JS4060 JS4045	120~230	BT40	0.1~0.8	5,310	1,590	4.8	3,980	1,590	12.7
			BT50		vc=200m/min fz=0.1mm/t ap=0.5mm ae=0.5DCX			vc=200m/min fz=0.2mm/t ap=1mm ae=0.5DCX		
Carbon & Alloy steels (30~40HRC)	JS4060 JS4045	100~200	BT40	0.08~0.6	3,980	960	2.9	2,980	890	7.1
			BT50		vc=150m/min fz=0.08mm/t ap=0.5mm ae=0.5DCX			vc=150m/min fz=0.15mm/t ap=1mm ae=0.5DCX		
Carbon & Alloy steels (40~45HRC)	JP4120 JS4045	60~150	BT40	0.08~0.3	2,650	640	1.9	1,990	600	2.9
			BT50		vc=100m/min fz=0.08mm/t ap=0.5mm ae=0.5DCX			vc=100m/min fz=0.15mm/t ap=0.6mm ae=0.5DCX		
Stainless steels SUS	JM4160	150~240	BT40	0.1~0.8	4,770	1,430	4.3	3,580	1,430	11.4
			BT50		vc=180m/min fz=0.1mm/t ap=0.5mm ae=0.5DCX			vc=180m/min fz=0.2mm/t ap=1mm ae=0.5DCX		
Cast irons FC, FCD	JP4120	100~220	BT40	0.1~1.0	4,770	1,430	4.3	3,580	1,430	11.4
			BT50		vc=180m/min fz=0.1mm/t ap=0.5mm ae=0.5DCX			vc=180m/min fz=0.2mm/t ap=1mm ae=0.5DCX		
Hardened steels (45~50HRC)	JP4120 JP4105	60~100	BT40	0.05~0.3	2,120	510	0.9	1,590	320	1.3
			BT50		vc=80m/min fz=0.08mm/t ap=0.3mm ae=0.5DCX			vc=80m/min fz=0.1mm/t ap=0.5mm ae=0.5DCX		
Hardened steels (50~60HRC)	※ ₁ JP4105	50~100	BT40	0.05~0.2	1,860	280	0.5	1,390	280	0.7
			BT50		vc=70m/min fz=0.05mm/t ap=0.3mm ae=0.5DCX			vc=70m/min fz=0.1mm/t ap=0.3mm ae=0.5DCX		

※₁: [JP4105] insert's grade specialized in High hardened steel is not suitable for Non-heat-treated steel material.

※₂: [JS4060] [JM4160] is recommended under heavy interrupt cutting.

[Note]

- ① Please note that the JS Coating does not cause a reaction in conductive touch sensors.
- ② Due to fire risks do not use neat cutting oil as a coolant.
- ③ The evacuation of swarf can cause burns, cuts or damage to the eyes please ensure the correct safety cover is fitted around the machine, and necessary personal protection equipment is worn by the machine operator.
- ④ These conditions are for general guidance; in actual machining conditions adjust the parameters according to your actual machine and work-piece conditions.
- ⑤ If vibrations are a concern due to the cutting conditions, adjust conditions by
1. reducing cutting depth (ap) or 2. reducing per-flute feed rate (fz).
- ⑥ In the case of slotting, feed speed could be down to 70% of the whole.
- ⑦ In steel exceeding 60HRC, such as dice steel between the colds, please set the sending (fz) value per one edge about to 1/2.

	φ20 (2 Flutes r4)			φ25 (2 Flutes r5)			φ32 (3 Flutes r5)			φ40 (4 Flutes r5)			Work material
	Revolution <i>n</i> min ⁻¹	Feed speed <i>V_f</i> mm/min	Chip removal volume cm ³ /min	Revolution <i>n</i> min ⁻¹	Feed speed <i>V_f</i> mm/min	Chip removal volume cm ³ /min	Revolution <i>n</i> min ⁻¹	Feed speed <i>V_f</i> mm/min	Chip removal volume cm ³ /min	Revolution <i>n</i> min ⁻¹	Feed speed <i>V_f</i> mm/min	Chip removal volume cm ³ /min	
	3,980	3,180	28.6	3,180	2,540	28.6	2,490	2,990	43.1	1,990	3,180	57.2	Mild steels (200HB or less)
	v _c =250m/min f _z =0.4mm/t a _p =1.5mm a _e =0.3DCX												
	3,980	3,180	47.7	3,180	2,540	47.6	2,490	2,990	71.8	1,990	3,180	95.4	Carbon & Alloy steels (30HRC or less)
	v _c =250m/min f _z =0.4mm/t a _p =1.5mm a _e =0.5DCX												
	3,180	2,540	22.9	2,550	2,040	23	1,990	2,390	34.4	1,590	2,540	45.7	Carbon & Alloy steels (30~40HRC)
	v _c =200m/min f _z =0.4mm/t a _p =1.5mm a _e =0.3DCX												
	3,180	2,540	38.1	2,550	2,040	38.3	1,990	2,390	57.4	1,590	2,540	76.2	Carbon & Alloy steels (30~40HRC)
	v _c =200m/min f _z =0.4mm/t a _p =1.5mm a _e =0.5DCX												
	2,390	960	8.6	1,910	760	8.6	1,490	890	12.8	1,190	950	17.1	Carbon & Alloy steels (30~40HRC)
	v _c =150m/min f _z =0.2mm/t a _p =1.5mm a _e =0.3DCX												
	2,390	1,430	21.5	1,910	1,150	21.6	1,490	1,340	32.2	1,190	1,430	42.9	Carbon & Alloy steels (40~45HRC)
	v _c =150m/min f _z =0.3mm/t a _p =1.5mm a _e =0.5DCX												
	1,590	480	2.9	1,270	380	2.9	990	450	4.3	800	480	5.8	Carbon & Alloy steels (40~45HRC)
	v _c =100m/min f _z =0.15mm/t a _p =1mm a _e =0.3DCX												
	1,590	640	6.4	1,270	510	6.4	990	590	9.4	800	640	12.8	Stainless steels SUS
	v _c =100m/min f _z =0.2mm/t a _p =1mm a _e =0.5DCX												
	3,180	1,590	14.3	2,550	1,280	14.4	1,990	1,490	21.5	1,590	1,590	28.6	Stainless steels SUS
	v _c =200m/min f _z =0.25mm/t a _p =1.5mm a _e =0.3DCX												
	2,860	1,716	25.7	2,290	1,370	25.7	1,790	1,610	38.6	1,430	1,720	51.6	Cast irons FC, FCD
	v _c =180m/min f _z =0.3mm/t a _p =1.5mm a _e =0.5DCX												
	2,860	2,290	20.6	2,290	1,830	20.6	1,790	2,150	31	1,430	2,290	41.2	Cast irons FC, FCD
	v _c =180m/min f _z =0.4mm/t a _p =1.5mm a _e =0.3DCX												
	2,860	2,860	42.9	2,290	2,290	42.9	1,790	2,690	64.6	1,430	2,860	85.8	Hardened steels (45~50HRC)
	v _c =180m/min f _z =0.5mm/t a _p =1.5mm a _e =0.5DCX												
	1,270	380	2.3	1,020	310	2.3	800	360	3.5	640	380	4.6	Hardened steels (45~50HRC)
	v _c =80m/min f _z =0.15mm/t a _p =1mm a _e =0.3DCX												
	1,270	380	3.8	1,020	310	3.9	800	360	5.8	640	380	7.6	Hardened steels (50~60HRC)
	v _c =80m/min f _z =0.15mm/t a _p =1mm a _e =0.5DCX												
	1,110	220	1.3	890	170	1.2	690	200	1.9	560	230	2.8	Hardened steels (50~60HRC)
	v _c =70m/min f _z =0.1mm/t a _p =1mm a _e =0.3DCX												
	1,110	220	2.2	890	170	2.1	690	200	3.2	560	230	4.6	Hardened steels (50~60HRC)
	v _c =70m/min f _z =0.1mm/t a _p =1mm a _e =0.5DCX												

Ramping, Helical Milling, Feeding toward Z-AXIS

There are restrictions to ramp angle (θ) and cutting depth (a_p) toward Z-axis because of designs of cutting edge.

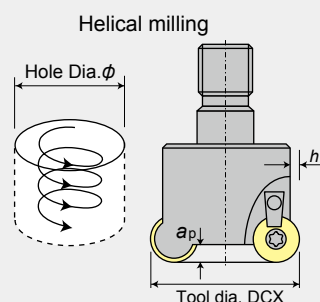
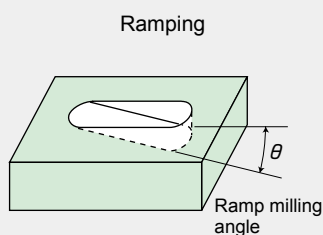

Tool dia. DCX	(mm)									
	φ12(r2.5)	φ16(r3.5)	φ20(r4)	φ22(r4)	φ25(r5)	φ28(r5)	φ30(r5)	φ32(r5)	φ40(r5)	
Recommended θ	Below 2 degrees		Below 3 degrees							
<i>h</i>	0.8	1	1	2	2	2	0.5	1.5	2	
<i>a_p</i>	0.8	1	2	3	3	3	3	3	3	
Hole Dia.	17~22	22~30	28~38	32~42	34~48	40~54	44~58	48~62	64~78	

[Note] Due to swarf evacuation wear safety glasses in the vicinity of the operation.

Cutting performance

Features

01 High-feed machining is possible by using the round-insert.

- It is able to feed two or three times faster than conventional one.

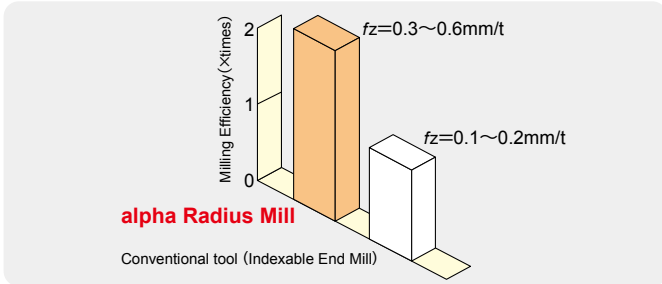

02 Strong double-Clamping Structure

- There could be some troubles like moving of the inserts or loosening of the screws, in case of single clamping like only wedges or screws. By strong double-clamping structure using both clamp screws and clamp pieces, those troubles have been solved.

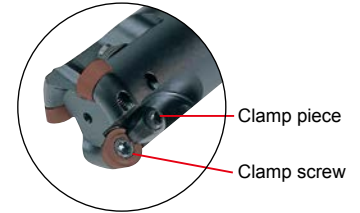

03 Ramping, Helical Milling, Feeding toward Z-AXIS

- There are restrictions to Ramp angle (θ) and cutting depth (a_p) toward Z-axis because of designs of cutting edge.

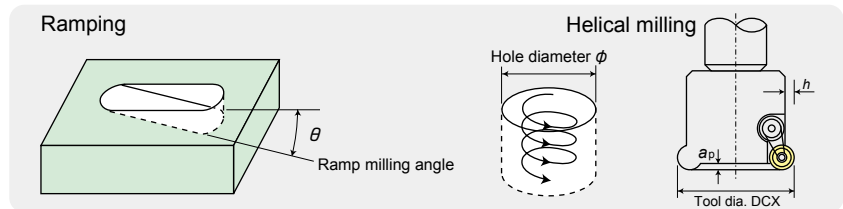

04 Direct machining is possible

- By application of slant milling, if there is no preparing hole, direct milling and expanding of pocket are possible. So that, there is no need to make preparing hole by using drills. Consequently, reduction of tools are possible.

alpha Radius Milling			Conventional milling
① No interference	② Some spaces	③ Some interferences	
4 times serial slant	Two ways slant		Preparing hole
(Slant + expand)	(Slant + expand)	(Slant + expand)	(Drilling + expand)

Cutting region

<1> Range comparison between r8 round-insert and r10 round-insert (conventional alpha Radius Mill RD type).

r8 round-insert is useful on the unstable cutting like Slotting or Die-Sinking.

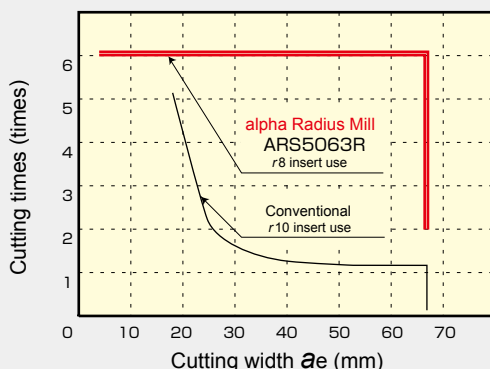

Work material: S50C(220HB)
 Tool dia. : $\phi 63 \times 3 \text{ NT}$
 $v_c = 168 \text{ m/min} (n = 850 \text{ min}^{-1})$
 $v_f = 800 \text{ mm/min} (f_z = 0.314 \text{ mm/t})$
 $a_p = 5 \text{ mm}$ Slotting

Conventional gets mill chattering after the second axial depths of cut. r8 inserted mill is able to machine smoothly until the sixis axial depths of cut.

<2> Milling range of the $\phi 20$ (Regular, Long, Extra Long)

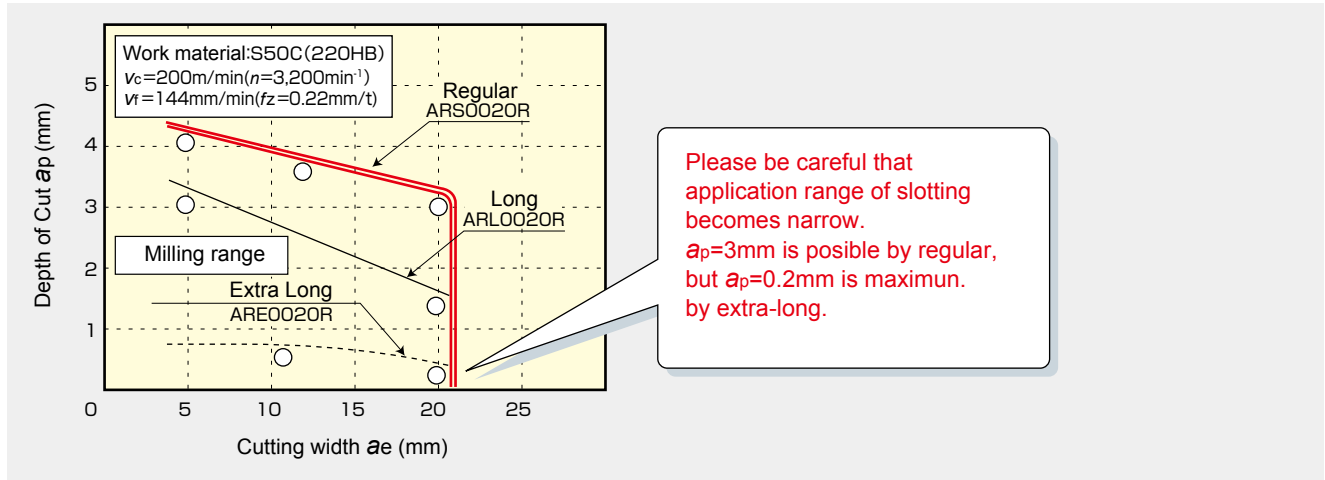

<3> Milling range of the $\phi 25$ (Regular, Long, Extra Long)

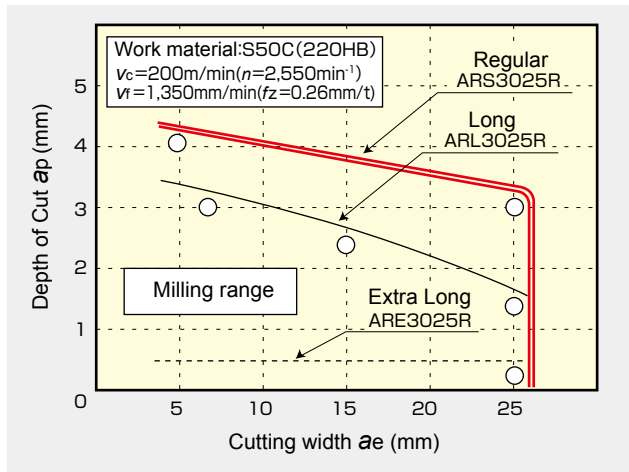

<4> Milling range of the $\phi 32$ (Regular, Long, Extra Long)

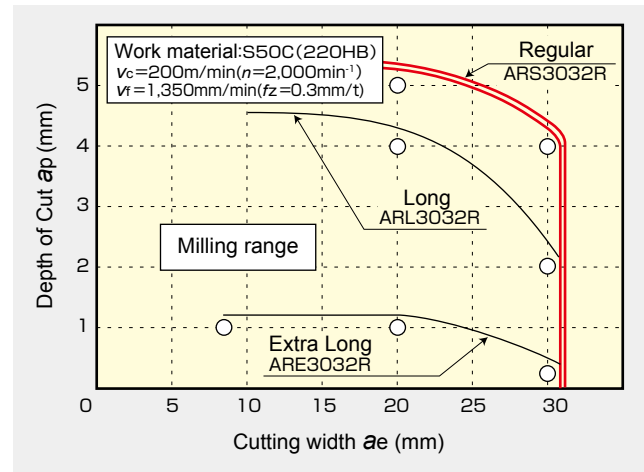

Field Data

No.	Tool dia. DCX	User	Insert grade	Work material	Cutting conditions			Result
					v_c m/min n (min ⁻¹)	v_f mm/min f_z (mm/t)	$a_p \times a_e$ mm	
1	50	Company A	JS4060	SCM (35HRC)	188 (1,200)	2,500 (0.69)	$a_p = 1.0$ $a_e = 1.0 \sim 2.0$	Enabled stable semi-finishing processing approx. 10 hours.
2	32	Company B	Equivalent to JP4120	P21 (40HRC)	200 (2,000)	3,000 (0.5)	$a_p = 0.5$ $a_e = 15$	1.5× the tool life of conventional products.
3	80	Company C	JS4060	S50C (220HB)	120 (480)	1,150 (0.6)	$a_p = 1.2$ $a_e = 50$	2× the tool life of conventional products.

Features comparing with conventional product

	AR type	Conventional A	Conventional B
Face milling	○	○	○
Side milling	○	○	○
Slotting	○	○	N/A
Helical milling	○	△	N/A
Scanning path	○	△	N/A
Contouring path	○	○	○
Chip removal	○	△	N/A
For difficult to cut material	○	△	△



The diagrams and table data are examples of test results, and are not guaranteed values.
 "MOLDINO" is a registered trademark of MOLDINO Tool Engineering, Ltd.



Attentions on Safety

1. Attentions regarding handling

- (1) When removing the tool from the case (package), be careful not to drop it on your foot or drop it onto the tips of your bare fingers.
- (2) When actually setting the inserts, be careful not to touch the cutting flute directly with your bare hands.

2. Attentions regarding mounting

- (1) When preparing for use, be sure that the inserts are firmly mounted in place and that they are firmly mounted on the arbor, etc.
- (2) If abnormal chattering occurs during use, stop the machine immediately and remove the cause of the chattering.

3. Attentions during use

- (1) Before use, confirm the dimensions and direction of rotation of the tool and milling work material.
- (2) The numerical values in the standard cutting conditions table should be used as criteria when starting new work. The cutting conditions should be adjusted as appropriate when the cutting depth is large, the rigidity of the machine being used is low, or according to the conditions of the work material.
- (3) The inserts are made of a hard material. During use, they may break and fly off. In addition, cutting chips may also fly off. Since there is a danger of injury to workers, fire, or eye damage from such flying pieces, a safety cover should be installed and safety equipment such as safety glasses should be worn to create a safe environment for work.
 - Do not use where there is a risk of fire or explosion.
 - Do not use non-water-soluble cutting oils. Such oils may result in fire.
- (4) Do not use the tool for any purpose other than that for which it is intended, and do not modify it.

MOLDINO Tool Engineering, Ltd.

Head Office
 Hulic Ryogoku Bldg. 8F, 4-31-11, Ryogoku, Sumida-ku, Tokyo, Japan 130-0026
 International Sales Dept. : TEL +81-3-6890-5103 FAX +81-3-6890-5128

Official Web Site

<https://www.moldino.com/en/>

Database for selection Cutting Tool Products [TOOL SEARCH]

TOOLSEARCH

Search Web

Europe

MOLDINO Tool Engineering Europe GmbH
 Itterpark 12, 40724 Hilden, Germany.
 Tel +49-(0)2103-24820 Fax +49-(0)2103-248230

Thailand

MITSUBISHI MATERIALS (THAILAND) CO., LTD.
 139/3 Moo 2, Tambon Khlong Chik, Amphoe Bang Pa-in,
 Phra Nakhon Si Ayutthaya 13160, Thailand
 Tel +66-3525-8024

America

MITSUBISHI MATERIALS U.S.A. CORPORATION
 Detroit office c/o RFM Inc. Customer service
 2001 Orndorf Drive, Brighton, MI 48116 U.S.A.
 Tel +1(248) 308-2620 Fax +1(248) 308-2627

India

Mitsubishi Materials India Private Limited
 H.O.: Prasad Enclave, #118/119, 1st Floor, 2nd Stage, 5th main, BBMP Ward #11, (New #38),
 Industrial Suburb, Yeshwanthpura, Bengaluru, 560 022, Karnataka, India.
 Tel +91-80-2204-3600

Mexico

MITSUBISHI MATERIALS MÉXICO S.A. DE C.V.
 Av. La Cañada No.16, Parque Industrial Bernardo Quintana, El Marques, Querétaro, CP 76246, México
 Tel +52-442-1926800

Brazil

MITSUBISHI MATERIALS BRASIL LTDA.
 Rua Cincinato Braga, 340 13° andar, Bela Vista – CEP 01333-010 São Paulo – SP., Brasil
 Tel +55(11)3506-5600 Fax +55(11)3506-5677

DISTRIBUTED BY: